



Exus X100E

TYPE	Pass-through dishwasher
LINE	EXUS LINE
BASKET	500x500
SIZE	620x770x1470/1930h





Reliability and ease of use: these are the keywords of the **EXUS** range. The **DIGIT panel** is a real highlight with its 4 washing cycles and an automatic drain cycle (with drain pump installed). On the control panel you can easily view the tank and boiler temperature, messages from the self-diagnosis system, the Scheduled Maintenance warning and the intelligent Start button, which changes colour to always show the dishwasher's status. The simple and extremely effective electronic board gives you the possibility to set and control the rinse and drain times, the wash and rinse temperatures and the relevant Thermostops, which are essential to guarantee an **excellent washing result**.

The **X100E** pass-through dishwasher is the right solution for businesses that are faced with washing a variety of dishes, proving capable of washing glasses, plates, medium-sized items and GN 1/1 trays in just 620 mm width, providing a maximum throughput of 60 baskets/hour (1080 dishes/hour). The pass-through models feature an easily removable basket support for easy cleaning and a rounded moulded tub with integral filters to ensure perfect drainage and absolute hygiene. The '**PUSH TO START**' cycle start system ensures less waste by preventing the start of empty washes.

The standard **double electric rinse-aid and detergent dispenser** ensures maximum hygiene at each wash cycle with great savings: the **moulded washing and rinsing arms** ensure reliability and durability. The bodywork is made entirely of **AISI 304 steel** and has been designed with all of the components in the front for **easy technical assistance**. Sturdy and reliable dishwashers to best deal with every moment of your day.

EN IEC 63136 COMPLIANT MODEL

View the [performance table](#)

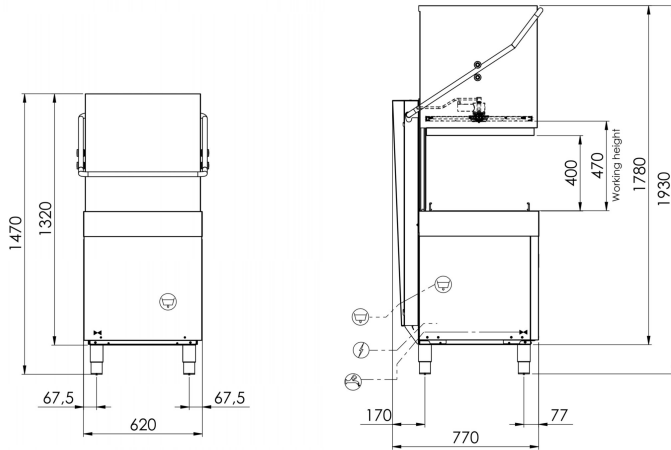

DISHWASHERS FEATURES EXUS LINE X100E

Dimensions - (mm) L - P - H	620x770x1470/1930h
n° baskets/hour - (+55°C)	60
Height glass max	390mm
Ø height plate max	415mm
Height pot max	390mm
LT bread basket	40 (H=390mm)
Trays	GN1/1
Tank heating element - Tank capacity	2,6kW - 24lt
Boiler heating element - Boiler capacity	5,4kW - 7,3lt
Washing pump	0,9kW / 1,2 Hp
Total power input / Current	6,52kW / 16A
Standard input voltage	400V3N 50Hz
Recommended inlet water temperature	+55°C
Water hardness	7÷10 °f
Water consumption per cycle (inlet suggested pressure 2 BAR)	2,0lt
Adjustable detergent and rinse-aid dispenser	STANDARD
STANDARD EQUIPMENT	
Cutlery insert	1
Basket for glasses dim.500x500x100mm	1
Basket for 18 dishes dim.500x500x100mm	2
OPTIONAL	
Booster pump kit 0,5Hp	●
Drain pump kit 32W with Ecoclean	●
Boiler heating element 9kW	●
Boiler heating element 9kW	●
Stainless steel tank filter	●
Reverse osmosis system	●
Basket for trays with 4 compartments dim.500x500x200mm	●
Inclined basket for wine glasses dim.500x500x170mm	●
Kit 4 Stainless steel feet 50-70mm	●

● = OPTIONAL INSTALLABILE, ■ = OPTIONAL NON INSTALLABILE