



## Smart SM991E

---

<b>TYPE</b>	Warewasher
<b>LINE</b>	SMART LINE
<b>BASKET</b>	1263x727 mm
<b>SIZE</b>	1440x860x2020/2300h

---



The dishwashers of the SMART line ensure maximum performance thanks to the standard Acquatech System which, through an atmospheric boiler and rinse pump, maintains constant temperature and pressure and optimum water consumption. SMART ensures a sanitising rinse cycle and proves to be the perfect choice for canteens, nursing homes, pastry shops, bakers and butchers where compliance with HACCP rules is essential. For those who seek glass perfection, it is possible to connect a Reverse Osmosis System which purifies water and reduces detergent and rinse-aid consumption, ensuring excellent results and perfect glasses without the need for hand drying.

The SM991E warewasher is the answer for those having to effectively wash within its two baskets, objects measuring up to 575x645x825(h)mm, thanks to the two wash pumps and two rinse pumps. It is suitable for washing baking trays, pots of various kinds, mixing bowls, utensils and even 52 dishes at each cycle as it is equipped with two baskets with a maximum productivity of 60 baskets/hour (3120 dishes/hour). The work height and the counterbalanced door facilitate loading while the double walls improve thermal-acoustic insulation. The rounded moulded tank with integral filters ensures maximum hygiene and perfect draining.

The electronic control allows you to manage various parameters to give you an absolute customisation level and the continuous self-diagnosis allows you to minimise machine downtime, suggesting some operations to be verified. The self-cleaning cycle at the end of the day cleans the wash tank and empties the boiler from the hot water, preventing limestone forming inside. The standard double peristaltic electric rinse-aid and detergent dispenser ensures the best result from each wash cycle with great savings thanks to the precise dosage managed by the electronic card; whereas, the moulded washing and rinsing arms ensure great reliability and durability. The Thermo-stop function checks that washing and rinsing begin only when the desired temperature is reached. The bodywork is made entirely of AISI 304 steel and has been designed with all components in the front to allow easy technical assistance. Sturdy and reliable dishwashers to best deal with every moment of your day.





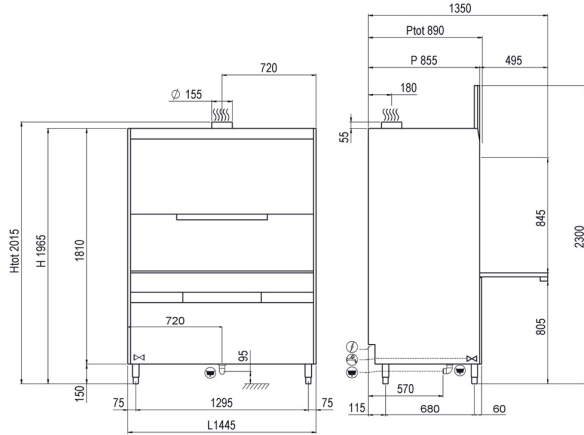

**DISHWASHERS FEATURES SMART LINE SM991E**

<b>Dimensions - (mm) L - P - H</b>	1440x860x2020/2300h
<b>n° baskets/hour - (+55°C)</b>	Max 30
<b>Height pot max</b>	830mm
<b>LT bread basket</b>	100lt
<b>Trays</b>	GN1/1 - 60x40 GN2/1 - 60x80
<b>Tank heating element - Tank capacity</b>	8,1kW - 100lt
<b>Boiler heating element - Boiler capacity</b>	8,1kW - 20lt
<b>Washing pump</b>	2kW - 2,7hp x2
<b>Total power input / Current</b>	12,1kW / 32A
<b>Standard input voltage</b>	400V3N - 50Hz
<b>Recommended inlet water temperature</b>	+55°C
<b>Water hardness</b>	7°f - 10°f
<b>Water consumption per cycle (inlet suggested pressure 2 BAR)</b>	4lt
<b>Adjustable detergent and rinse-aid dispenser</b>	STANDARD
<b>Acquatech system rinse</b>	STANDARD
<b>STANDARD EQUIPMENT</b>	
<b>8 division cutlery insert</b>	1
<b>Integral tank filter</b>	STANDARD
<b>Inox basket dim.600x670x100mm</b>	1
<b>Basket for trays with 5 compartments</b>	1
<b>Basket for trays 8 compartments</b>	1
<b>OPTIONAL</b>	
<b>Built-in drain pump 190W with Ecoclean</b>	●
<b>Boiler heating element 9kW</b>	●
<b>Boiler heating element 9kW</b>	●
<b>"SOFT Door" Opening/Closing System</b>	-

● = OPTIONAL INSTALLABILE, - = OPTIONAL NON INSTALLABILE