



Smart SM981E

TYPE	Warewasher
LINE	SMART LINE
BASKET	600x670
SIZE	775x810x1930/2215h





SM981E is the ideal choice for efficiently washing items up to **575x645x825(h) mm** in size inside its basket. It is suitable for washing **trays, various types of pots, planetary mixers, utensils**, and even **26 plates per cycle**, with a maximum productivity of **30 racks/hour (780 plates/hour)**. The working height and the **counterbalanced door** make loading operations easier, while the **double walls** improve thermal and acoustic insulation. The **moulded rounded tank with full filters** ensures maximum hygiene and perfect drainage.

The dishwashers in the **SMART** line ensure top performance thanks to the standard **Acquatech System**, which maintains **constant temperature and pressure** and optimizes water consumption through an **atmospheric boiler** and a **rinse pump**. SMART guarantees a **sanitizing rinse cycle** and is the perfect choice for **canteens, nursing homes, pastry shops, bakeries, and butcheries**, where HACCP compliance is essential. The practical **LCD display** simplifies every operation, from selecting the wash cycle to monitoring the machine status. Its wide range of parameters allows the dishwasher to be customized according to your needs, from **temperature settings** to **detergent** and **wash time** adjustments.

For those seeking **glass perfection**, it is possible to connect a **Reverse Osmosis System** that purifies water and reduces **detergent** and **rinse aid** consumption, ensuring excellent results and perfectly clean glasses without the need for manual drying.

The **electronic control** allows you to manage various parameters for a high level of customization based on your needs, while the **self-diagnosis** function helps minimize downtime by suggesting simple actions to resolve any issues. The **self-cleaning cycle** at the end of the day cleans the **wash tank** and **empties the boiler** of hot water, thus preventing limescale buildup. Thanks to the **Thermostop** function, washing and rinsing only begin once the desired temperature is reached. The standard **peristaltic electric double dispenser** for detergent and rinse aid guarantees the best result from each cycle with significant savings, thanks to the **precise dosing managed by the electronic board**. The **moulded wash and rinse arms** ensure great reliability and long-term durability. The **AISI 304 stainless steel body** is designed with all components accessible from the front for easy maintenance by technicians.



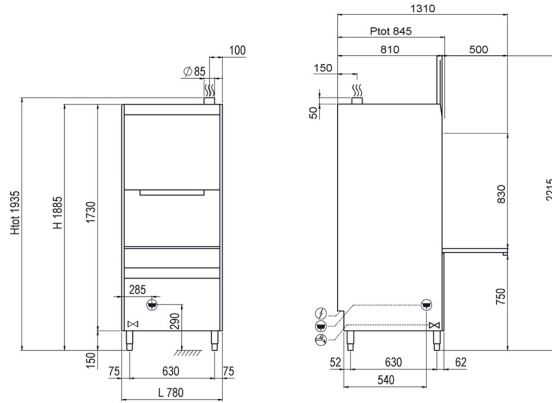

DISHWASHERS FEATURES SMART LINE SM981E

Dimensions - (mm) L - P - H	775x810x1930/2215h
n° baskets/hour - (+55°C)	Max 30
Ø height plate max	630mm
Height pot max	830mm
LT bread basket	100
Trays	GN1/1 - 60x40 GN2/1 - 60x80
Tank heating element - Tank capacity	4,5kW - 37l
Boiler heating element - Boiler capacity	5,4kW - 12l
Washing pump	2,0kW / 2,7Hp
Total power input / Current	7,4kW / 16A
Standard input voltage	400V3N - 50Hz
Recommended inlet water temperature	+55°C
Water hardness	7°f - 10°f
Water consumption per cycle (inlet suggested pressure 2 BAR)	2,4 l
Adjustable detergent and rinse-aid dispenser	STANDARD
Acquatech system rinse	STANDARD
STANDARD EQUIPMENT	
8 division cutlery insert	1
Integral tank filter	STANDARD
Inox basket dim.600x670x100mm	1
Basket for trays with 5 compartments	1
OPTIONAL	
Optional 230V/3+T	●
Drain pump kit 32W with Ecoclean	●
Boiler heating element 9kW	●
Reverse osmosis system	●
"SOFT Door" Opening/Closing System	-
"Energy Pro Green" System	●

● = OPTIONAL INSTALLABILE, ■ = OPTIONAL NON INSTALLABILE