



Smart SM951E

TYPE	Warewasher
LINE	SMART LINE
BASKET	600x670
SIZE	775x810x1435h



The dishwashers of the SMART line ensure maximum performance thanks to the standard Acquatech System which, through an atmospheric boiler and rinse pump, maintains constant temperature and pressure and optimum water consumption. SMART ensures a sanitising rinse cycle and proves to be the perfect choice for canteens, nursing homes, pastry shops, bakers and butchers where compliance with HACCP rules is essential. For those who seek glass perfection, it is possible to connect a Reverse Osmosis System which purifies water and reduces detergent and rinse-aid consumption, ensuring excellent results and perfect glasses without the need for hand drying.

Thanks to its dimensions, the SM951E model can be used both as large dishwasher and as warewasher. In fact, its basket can wash 26 dishes per cycle, GN1/1 baking trays, baking trays and 600x400 dough trays and objects measuring up to 575x645x445(h)mm with a maximum productivity of 30 baskets/hour (780 dishes/hour). The practical work height facilitates loading while the double walls improve thermal-acoustic insulation. The rounded moulded tank with integral filters ensures maximum hygiene and perfect draining.

The electronic control allows you to manage various parameters to give you an absolute customisation level and the continuous self-diagnosis allows you to minimise machine downtime, suggesting some operations to be verified. The self-cleaning cycle at the end of the day cleans the wash tank and empties the boiler from the hot water, preventing limestone forming inside. The standard double peristaltic electric rinse-aid and detergent dispenser ensures the best result from each wash cycle with great savings thanks to the precise dosage managed by the electronic card; whereas, the moulded washing and rinsing arms ensure great reliability and durability. The Thermo-stop function checks that washing and rinsing begin only when the desired temperature is reached. The bodywork is made entirely of AISI 304 steel and has been designed with all components in the front to allow easy technical assistance. Sturdy and reliable dishwashers to best deal with every moment of your day.



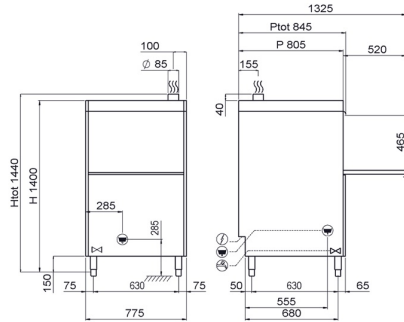

DISHWASHERS FEATURES SMART LINE SM951E

Dimensions - (mm) L - P - H	775x810x1435h
n° baskets/hour - (+55°C)	Max 30
Ø height plate max	430mm
Height pot max	445mm
LT bread basket	60 (H=445mm)
Trays	GN1/1-60x40
Tank heating element - Tank capacity	4,5kW - 37l
Boiler heating element - Boiler capacity	5,4kW - 12l
Washing pump	2,0kW / 2,7Hp
Total power input / Current	7,4kW / 16A
Standard input voltage	400V - 50Hz
Recommended inlet water temperature	+55°C
Water hardness	7°f - 10°f
Water consumption per cycle (inlet suggested pressure 2 BAR)	2,4 l
Adjustable detergent and rinse-aid dispenser	STANDARD
Acquatech system rinse	STANDARD

STANDARD EQUIPMENT

8 division cutlery insert	1
Integral tank filter	STANDARD
Inox basket dim.600x670x100mm	1
Basket for trays with 5 compartments	1

OPTIONAL

Optional 230V/3+T	●
Drain pump kit 32W with Ecoclean	●
Boiler heating element 9kW	●
Reverse osmosis system	●
"Energy Pro Green" System	●
Wi-Fi connection module	●

● = OPTIONAL INSTALLABILE, ■ = OPTIONAL NON INSTALLABILE