



Smart SM84E

TYPE	Warewasher
LINE	SMART LINE
BASKET	500x600
SIZE	585x715x1450h





The dishwashers of the **SMART** line ensure maximum performance thanks to the standard Acquatech System which, through an atmospheric boiler and rinse pump, maintains constant temperature and pressure and optimum water consumption. **SMART** ensures a sanitising rinse cycle and proves to be the perfect choice for canteens, nursing homes, pastry shops, bakers and butchers where compliance with HACCP rules is essential. For those who seek glass perfection, it is possible to connect a **Reverse Osmosis System** which purifies water and reduces detergent and rinse-aid consumption, ensuring excellent results and perfect glasses without the need for hand drying.

The simple electronic board control system makes it possible to set and control the rinsing and draining times and temperatures and the relevant **Thermostops**, crucial for ensuring excellent final results. With the control panel you can choose one of its 4 washing cycles and one automatic drain cycle (with installed drain pump), easily view on the display the tank and boiler temperature, the messages of the Self-diagnosis system and the Scheduled Maintenance warning. The smart Start button changes colour to always keep you up-to-date on the dishwasher status with the greatest ease.

The **SM84E** model is the suitable solution for restaurateurs who must wash a large number of dishes (max 22/basket), baking trays and trays with reduced space, with guarantee of a maximum productivity of 40 baskets/hour (880 dishes/hour). In fact, thanks to the dedicated basket, you can wash GN 1/1 65 mm high baking trays, 600x400 dough trays and cake trays, while maintaining the measurements of a comfortable undercounter dishwasher. Thanks to the powerful **wash pump** and Ø30mm washing arms, removing the most stubborn dirt will not be your problem. The **drain pump** optional allows you to handle the drain automatically and perform a partial replacement of clean water at each wash cycle.

The electronic control allows you to manage various parameters to give you an absolute customisation level and the continuous self-diagnosis allows you to minimise machine downtime, suggesting some operations to be verified. The self-cleaning cycle at the end of the day cleans the wash tank and empties the boiler from the hot water, preventing limestone forming inside. The standard double peristaltic electric rinse-aid and detergent dispenser ensures the best result from each wash cycle with great savings thanks to the precise dosage managed by the electronic card; whereas, the moulded washing and rinsing arms ensure great reliability and durability. The Thermo-stop function checks that washing and rinsing begin only when the desired temperature is reached. The bodywork is made entirely of **AISI 304** steel and has been designed with all components in the front to allow easy technical assistance. Sturdy and reliable dishwashers to best deal with every moment of your day.



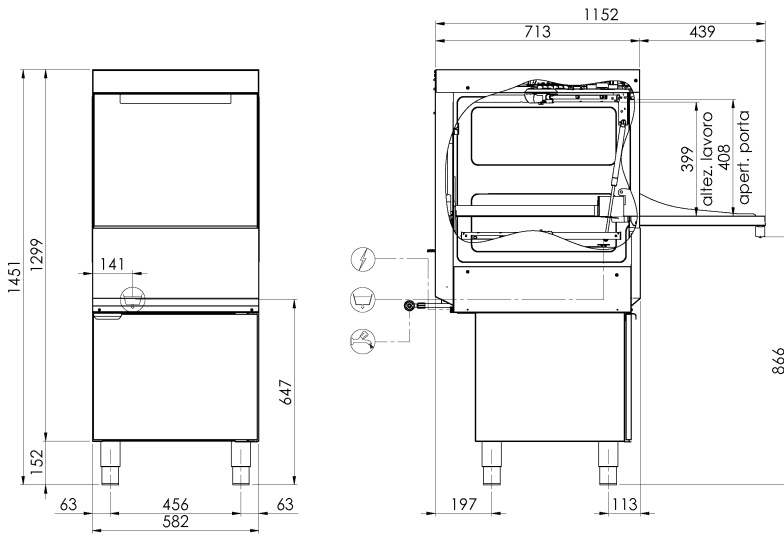

⊗ = cavo Ø14 (5x2,5), lungh. 2800mm ⊕ = 3/4" Gas F., lungh. 1200mm ⊖ = manicotto dritto Ø24, lungh. 1500mm

DISHWASHERS FEATURES SMART LINE SM84E

Dimensions - (mm) L - P - H	585x715x1450h
n° baskets/hour - (+55°C)	Max 40
Height glass max	340mm
Ø height plate max	370mm
Height pot max	340mm
Trays	GN1/1 - 60x40 (Special basket required)
Tank heating element - Tank capacity	2,6kW - 30l
Boiler heating element - Boiler capacity	8,1kW - 7,3lt
Washing pump	0,9kW / 1,2Hp
Total power input / Current	9kW / 16A
Standard input voltage	400V3N - 50Hz
Recommended inlet water temperature	+55°C
Water hardness	7°f - 10°f
Water consumption per cycle (inlet suggested pressure 2 BAR)	2,4 l
Adjustable detergent and rinse-aid dispenser	STANDARD
Acquatech system rinse	STANDARD

STANDARD EQUIPMENT

Cutlery insert	2
Basket for trays 10/12 compartments 500x600x100mm	1
Basket for glasses dim.500x600x100mm	1
Basket for 22 dishes dim.500x600x100mm	1

OPTIONAL

Optional 230V/3+T	●
Drain pump kit 32W with Ecoclean	●
Boiler heating element 9kW	●
Reverse osmosis system	●
Basket for trays with 4 compartments dim.500x500x200mm	●
Inclined basket for wine glasses dim.500x500x170mm	●
Kit 4 Stainless steel feet 50-70mm	●
"SOFT Door" Opening/Closing System	-
Start Cycle "SOFT Start"	-

● = OPTIONAL INSTALLABILE, - = OPTIONAL NON INSTALLABILE