



Smart SM100E

TYPE	Pass-through dishwasher
LINE	SMART LINE
BASKET	500X500
SIZE	620x770x1435/1900h



SM100E is the pass-through dishwasher designed to deliver **high performance and perfect hygiene** thanks to the **Acquatech System with Break Tank**, which keeps water temperature, pressure and flow rate constant throughout the cycle. Rinsing is always performed under optimal conditions, reducing consumption and ensuring **high-temperature sanitization**. With a width of only 620 mm, it can wash glasses, dishes, utensils and **GN 1/1 trays**, with a maximum productivity of **60 racks/hour** (1080 dishes/hour). The **DIGIT control panel** offers 4 wash cycles and one automatic drain cycle (with drain pump installed), while the display allows you to check tank and boiler temperature, self-diagnosis messages, maintenance alerts and machine status via the **SMART START** button. The electronic board allows time and temperature adjustment with **Thermostop activation** to ensure impeccable rinsing. The **PUSH TO START** system prevents accidental starts and waste. The rounded molded tank and integral filters simplify cleaning and improve hygiene. The **dual rinse aid and detergent dispenser** ensures efficiency and savings. Structure in **AISI 304 stainless steel** with front access to technical components.

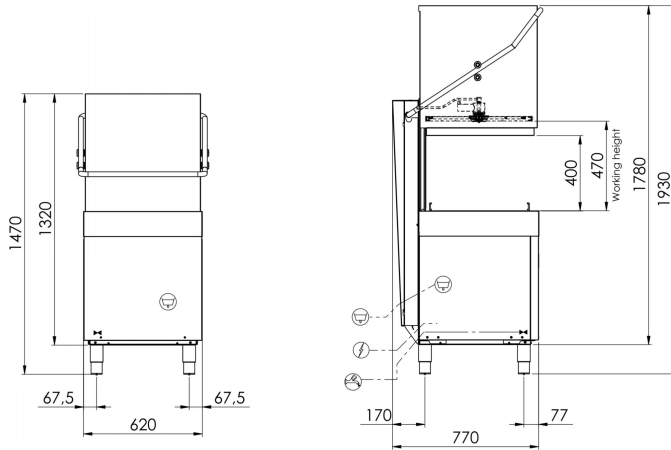

DISHWASHERS FEATURES SMART LINE SM100E

Dimensions - (mm) L - P - H	620x770x1435/1900h
n° baskets/hour - (+55°C)	Max 60
Height glass max	390mm
Ø height plate max	415mm
Height pot max	390mm
LT bread basket	40 (H=390mm)
Trays	GN1/1
Tank heating element - Tank capacity	2,6kW - 24lt
Boiler heating element - Boiler capacity	5,4kW - 7,3lt
Washing pump	1,12kW / 1,5 Hp
Total power input / Current	6,52 kW / 16A
Standard input voltage	400V3N+T / 230V 50Hz
Recommended inlet water temperature	+55°C
Water hardness	7±10 °f
Water consumption per cycle (inlet suggested pressure 2 BAR)	2,0lt GUARANTEED
Adjustable detergent and rinse-aid dispenser	ELECTRIC
Acquatech system rinse	si
STANDARD EQUIPMENT	
Basket for glasses dim.500x500x100mm	1
Basket for 18 dishes dim.500x500x100mm	2
8 division cutlery insert	1
OPTIONAL	
Optional 230V/3+T	●
Booster pump kit 0,5Hp	-
Drain pump kit 32W with Ecoclean	●
Boiler heating element 9kW	●
Stainless steel tank filter	●
Inclined basket for wine glasses dim.500x500x170mm	●
Basket for trays with 4 compartments dim.500x500x200mm	●
Inclined basket for wine glasses dim.500x500x170mm	●
Kit 4 Stainless steel feet 50-70mm	-
Remote control with LCD display	●

● = OPTIONAL INSTALLABILE, ▣ = OPTIONAL NON INSTALLABILE